

CR2477N

3V Lithium Battery
Swiss Made

Technical Data Sheet

Specifications

Chemical System	Li/MnO ₂
Nominal Voltage	3 V
Rated Capacity	950 mAh
Standard Discharge Current	1.0 mA
Max. Cont. Discharge Current	2.5 mA
Average Weight	8.3 g
Temperature Range	-30 - +70 °C
Self Discharge at 25 °C	< 1% / year

Dimensions

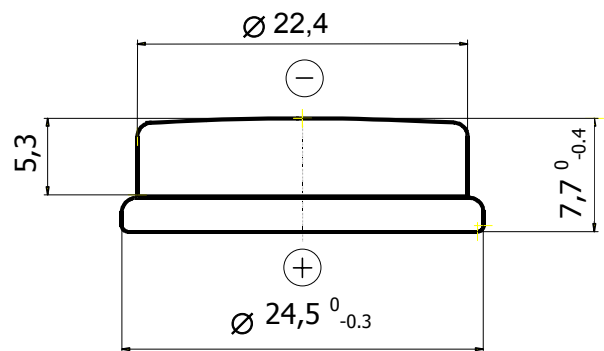

Performance

Discharge performance at 23°C

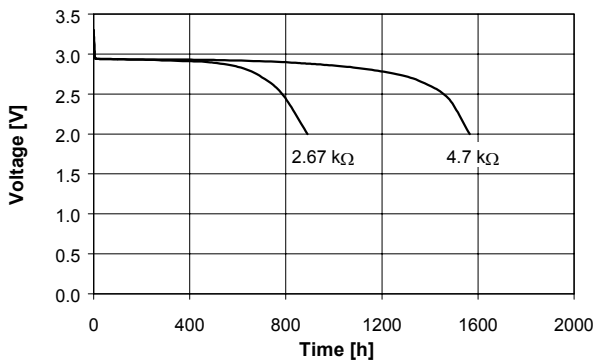

Discharge performance at 23°C

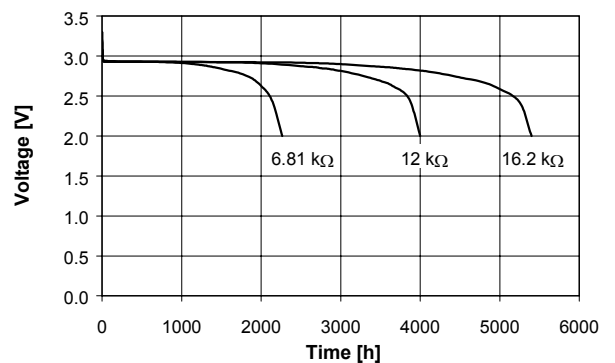

Temperature performance Load 4.7kΩ

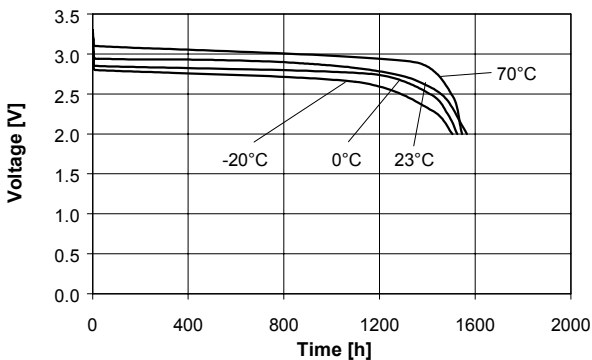

Cell capacity at various loads

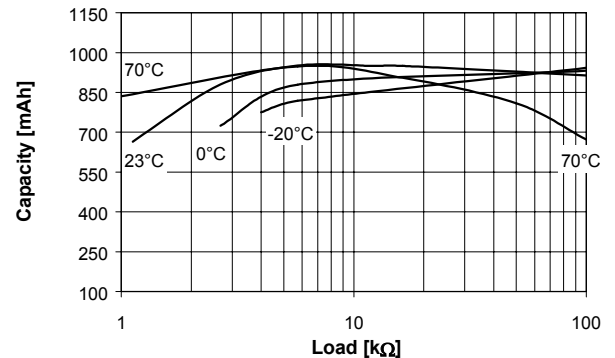

Rev. CR2477N.03 10/01